

# LiberatorStairlift

Designed to make a difference

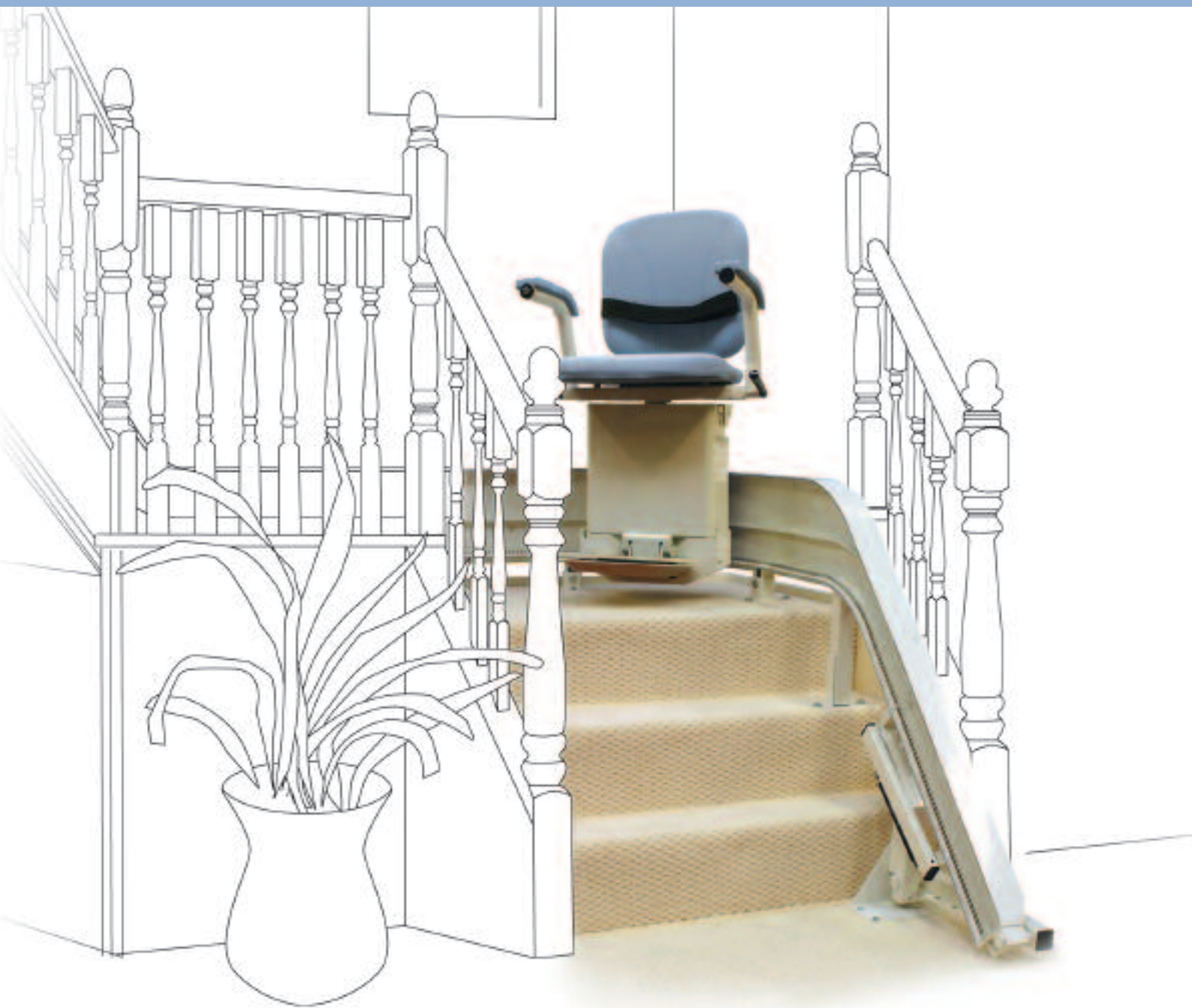

# Putting you in control

The "**Liberator**" curved stairlift has been designed to offer maximum safety reliability and comfort to those who find difficulty in negotiating stairways in both the home and in public premises.

The unique battery powered drive system ensures smooth quiet operation even in the case of a power cut.

Light finger tip pressure on the joy stick, in the direction of travel, provides effortless control, ideal for users with limited hand movement.

The option of push button control is available if preferred.

Call/send stations which are positioned at the top and bottom of the stairs are operated by infra red handsets avoiding the need for electric wiring installation.

## Proven technology

Manufactured and designed in the UK the "**Liberator**" embodies proven technology to ensure maximum safety and reliable service.

The self sustaining gearbox is backed up by an over speed governor which will automatically stop the lift should it exceed its normal design speed.

Pressure sensitive edges on the foot rest and chassis ensure that the lift will automatically stop should it meet an obstruction on the stairs.

## Able to fit in the tightest of turns

The "**Liberator**" stairlift chassis rides on a sturdy rail section custom built for each stairway to optimise the available space. It provides the user with a stable smooth ride quality of maximum comfort.

The rail which is bracket mounted to the stairs to ensure minimum disruption to decoration is close fitting to the wall resulting in maximum available space for other stairway users.

The versatile rail can be manufactured to fit the most complicated of stairways and the ability to negotiate the tightest of turns enables the "**Liberator**" to be installed in many locations no other stairlift manufacturer can accommodate.





# Designed with you in mind

When parked the compact chassis can be folded away to only 14" (356 mm) overall width resulting in minimal intrusion into stair, hall and landing areas.

Manual or powered hinge mechanisms with integral control are also available to avoid door obstruction at the bottom of the stairs.

As standard the seat is fitted with a lever operated swivel seat facility with individual folding arm rests designed to offer maximum assistance when aligning at the top or bottom of the stairs.

The "**Liberator**" stairlift seat options include a perch seat arrangement for users with limited knee or hip movement and a snug seat for the smaller user. The standard seat belt can be replaced by an optional harness on request.

A key switch locking option is available to avoid unwelcome or unauthorised usage.

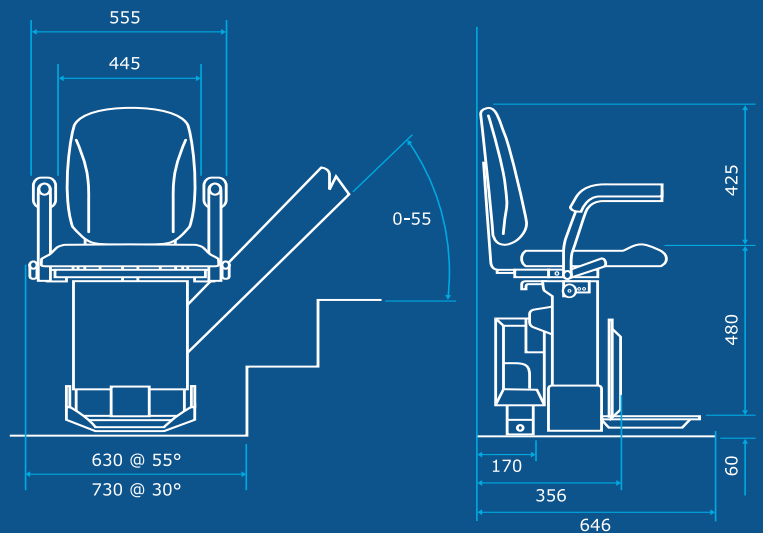

Further information is available on request.

Maximum safe working load 135kg.



# Customised to your requirements

## Configurations

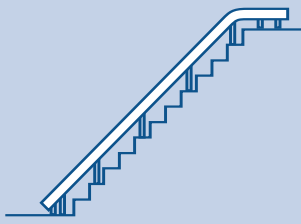

A. Top Overrun



C. 90° Flat Turn



F. 90° Short Radius



I. 90° Large Radius

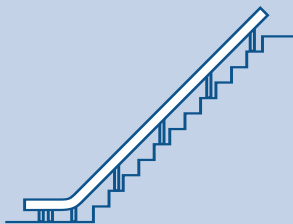

A1. Bottom Overrun



D. 180° Flat Turn



G. 180° Short Radius



J. 180° Large Radius

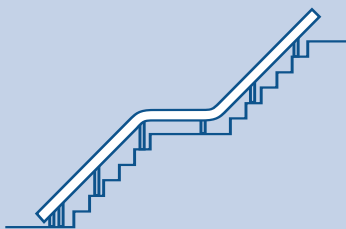

B. Intermediate Landing



E. Double 90° Flat Turn

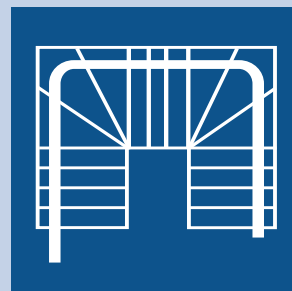

H. Double 90° Short Radius



K. 270° Large Radius

## Flexibility

The seat and backrest of the “**Liberator**” stairlift have been designed to provide maximum comfort and ride quality. Upholstered in easy clean flame resistant fabric they are available in a number of sensitively chosen colours to suit your personal preference and décor.



Colours illustrated are for reference only and may vary.

Distributed by



Manufactured by:

**Powerdrive PSR Limited**

Sydenham Industrial Estate, Leamington Spa, Warwickshire CV31 1PZ

**Telephone: 00 44 (0)1926 452747**

Fax: 00 44 (0)1926 315400